

# Refrigerators & Freezers ◆ INSTALLATION • OPERATION

---

English

---

---

---

---

---

---

---

---

Before installing your Tundra unit,  
refer to L-2083: Tundra Installation  
Check List.



---

# Table of Contents

---

<b>Refrigerators &amp; Freezers • Installation</b>	<b>3</b>
Warnings .....	3
<b>Locating the Data Plate</b>	<b>4</b>
<b>Inspection and Handling</b>	<b>4</b>
<b>Electrical Connection</b>	<b>5</b>
DC Only Wiring .....	5
AC/DC Wiring (AC/DC Converter) .....	5
Portable Unit Wiring .....	5
.....	5
Portable Units - Special Considerations .....	6
DANFOSS Compressor Data .....	6
ABYC Standards - ABYC Guidelines E9 - Direct Current .....	8
ABYC Standards - ABYC Guidelines E8 - Alternating Current/Amperage .....	8
<b>Final Installation Notes</b>	<b>9</b>
<b>Refrigerators &amp; Freezers • Operation</b>	<b>10</b>
Warnings .....	10
<b>Temperature Control</b>	<b>10</b>
Rotary Thermostat (Knob Control) .....	10
Digital Thermostat (Solid State Control) .....	11
<b>Loading the Appliance</b>	<b>11</b>
<b>Refrigerators &amp; Freezers • Maintenance</b>	<b>12</b>
<b>Defrosting</b>	<b>12</b>
<b>Cleaning</b>	<b>12</b>
Cleaning the Exterior .....	12
Cleaning the Interior .....	12
Cleaning the Condenser .....	12
<b>Refrigerators &amp; Freezers • Trouble-Shooting</b>	<b>13</b>
Appliance Does Not Operate .....	13
Excessive Appliance Noise .....	13
Insufficient Refrigerating Capacity .....	14
<b>Manufacturer's Limited Warranty Agreement</b>	<b>15</b>
<b>Dometic Corporation – Tundra Schedule of Limited Warranty Allowances</b>	<b>16</b>
<b>WARNINGS</b>	<b>17</b>
<b>Description of Drawings/Diagrams</b>	<b>18-26</b>

---

# Refrigerators & Freezers • Installation

---

## **Warnings**

**This section of the manual refers to essential safety Installation information for all compressor-type refrigerators and freezers (including Portable and Special Purpose Units), provided by Dometic Corporation.**

1. When replacing old appliances, before disposing of the old model, any locking device with hinging must be removed so that the door cannot be accidentally locked. All refrigerant must be removed according to current EPA regulations.
2. Unpacking and installation of the unit must be carried out with the utmost care. To avoid accidental injury use protective gloves, in particular for the models with a remote condensing unit.
3. After unpacking the appliance ensure that it is not damaged in any way. Notification of damage must be supplied to the dealer no later than 24 hours from the purchase date. The appliance must be used exclusively for the conservation of food and drinks.
4. **Install the appliance away from any heat sources and allow for sufficient ventilation. (See Installation Section)**
5. After installation, wait at least one hour before switching on the appliance. This precaution protects the compressor from shipping mishaps and ensures optimum refrigeration efficiency.
6. Before connecting the appliance to the power supply, check that the line voltage corresponds to specifications stated on the appliance dataplate and the compressor.
7. Ensure the safety of operation by proper grounding of the electrical system.
8. After installation, check that the appliance is not standing on the power supply cable.

For any installation problems call your dealer, or call Dometic Corporation at 804-746-1313 or 954-973-2477. Ask for the **Tundra** service department.

---

## Locating the Data Plate

---

The dataplate bearing the model and serial number and technical data is located on the upper right-hand section, inside the appliance (for Portable units, it is located on the inside of the lid). An additional, identical dataplate is located on the compressor's electronic module.

The first three digits of the serial number indicate the Year and Week of manufacture.

Example: If your Serial Number = **0123456** it means:

0 = Year 2000    12 = 12th Week of the Year    3456 = Sequential Unit Number

---

## Inspection and Handling

---

Ensure that the appliance is not damaged. Any damage resulting from transport must be reported to the dealer no later than 24 hours after delivery. A notice is printed on the top of each box, describing the general procedures required.

Handle the appliance with care. Take care when positioning the unit (especially in the case of refrigerators with remote condensing units), to avoid any obstruction to the connection lines. Always ensure that the appliance and remote condensing unit (where applicable), are installed on a dry, flat surface that will not allow it to slide around.

Ventilation is a requirement for the condensing system. Allow for air entry and discharge for the condensing system. Air entry and discharge requires a minimum of 50 total sq. inches each. (A T-80 unit requires a minimum of 75 total sq. inches for air entry and discharge.) A lower entry, and upper discharge is preferred. (See Fig. 5, page 21)

When installing the appliance in campers, motorhomes etc., install air vents connected directly to the outside.

Install appliance away from heat sources in a dry and well-ventilated area. Avoid direct contact with water. **The appliances are not waterproof.**

---

## Electrical Connection

---

Before connecting the appliance to the power supply, check that the line voltage corresponds to the indications on the appliance rating plate and those of the compressor plate. This appliance complies with EC directive 89/336 governing radio suppression.

Noise emission levels are maintained below 70 dB(A).

### ***DC Only Wiring***

For Direct Current (DC) refrigerators, connect the appliance to the DC distribution center. A circuit breaker of 15 Amps (maximum) must be used if the system is 12VDC, and 10 Amps (maximum) if the system is 24VDC. **Make sure that proper polarity is maintained at all times.** Check that all grounding systems are in good working order. **The appliance must be wired and grounded in accordance with the ABYC Guideline E9.** (See ABYC Guidelines E9 pg. 8)

### ***AC/DC Wiring (AC/DC Converter)***

If the appliance is equipped with an AC/DC converter, then both AC and DC power may be used. The converter functions by converting AC power into DC power for the compressor. When the converter is connected to both AC and DC, and the AC power is on, then the unit will run on the AC power. However, if the AC power is lost, the unit will run on the DC power. If both types are to be used, connect the DC wiring to the DC distribution panel, and the AC wiring to the AC distribution panel, following ABYC guidelines. The converter may be connected to either AC or DC power only, if so desired.

For the DC wiring, follow the same instructions as stated in the 'DC Only Wiring' section. For the AC wiring, use a 10 Amp circuit breaker (maximum). **Make sure that proper polarity is maintained at all times.** Check that all grounding systems are in good working order. **The appliance must be wired and grounded in accordance with the ABYC Guideline E8.** (See ABYC Guidelines E8, pg. 8)

### ***Portable Unit Wiring***

The TPD23/AC models have AC and DC receptacles that are prewired to the unit. The TPD23 model has only the DC receptacle prewired. The TPD23AC model has both the AC and DC receptacles prewired.

Each unit comes equipped with the mating connector and cable as required (DC cable with TPD23 and both AC and DC cables with TPD23AC). These must be connected to their respective power sources as described in the wiring instructions listed above.

---

## **Portable Units - Special Considerations**

Since Portable units can be used in a variety of applications, and connected to a variety of power sources, the following must be considered:

- Cigarette lighters may not provide sufficient voltage and power to start and operate a portable unit. The unit may need to be wired separately from the lighter receptacle.
- Many DC outlets in vehicles (i.e. cigarette lighters, power outlets, etc.), are not powered when the ignition switch is turned to "Off". Check available outlets for this condition before leaving the unit unattended.
- Some DC outlets or receptacles remain powered when the ignition switch is turned OFF, but do not have enough voltage to restart the compressor when required. Check for this condition before leaving the unit unattended.
- Power outlets or receptacles that are connected directly to the battery, and have a higher amp fused circuit (40 amps vs. 15-20 amps) will generally restart the compressor with the ignition switch turned OFF.

**Caution must be taken when the unit is left unattended under these circumstances, as the battery will continue to drain down as the compressor cycles and runs. This can cause the battery voltage to drop too low to restart the vehicle's engine. The cut-out voltage that protects the compressor is 10.4 volts. Therefore, if the unit is to be operated for long periods of time without replenishing the battery, another power source may need to be provided or the unit should be shut off, and the contents removed.**

- Ambient conditions, wire sizes and battery quality can affect operation.

## **DANFOSS Compressor Data**

### **Voltage Range**

12V systems: From 10.4V to 17V

24V systems: From 22.8V to 31.5V

The electronic unit will calibrate automatically to the applied voltage. This means that if the battery voltage is less than 17V, the electronic unit assumes that it is working in a 12V system. If the voltage is higher than 17V, the electronic unit assumes that it is working in a 24V system. Consequently, the compressor does not run at power supply voltages between 17V and the desired battery protection cut-out voltage of 22.8V, for 24V systems.

### **Protection Systems**

The Danfoss compressor protection system facilitates protection against compressor overload and start failure, fan overload and electronic unit overheating as well as destructive battery discharge. When an overload protection is activated, the compressor enters a cycle in which it makes start attempts at approximately 60 second intervals until a successful start is achieved.

## Overload Protections

The compressor overload and start protection cuts off power to the compressor if the compressor speed drops below approximately 1,900 rpm, or if this motor speed is not reached during the start sequence. Possible reasons for overload protection activating could be too high refrigeration system pressures during operation or lack of pressure equalizing at start.

The fan overload protection stops the compressor if the fan current exceeds  $0.5 A_{(avg)}$  or  $1 A_{(peak)}$ .

An overheating of the electronic unit heat sink will cause the compressor to stop. Restart will occur automatically when a normal temperature has been reached. If a fan is installed, it will continue to run when the compressor stops, due to overload or electronic unit overheating.

## Voltage Protection

If a voltage outside any operational range is applied to the electronic unit, the compressor does not start, or it stops if the voltage limit is exceeded during operation. The compressor will restart automatically, approximately 1 minute after the supply voltage has reached the reset voltage within the range in question.

## Battery Protection

The Danfoss electronic unit provides protection as follows:

**Standard Battery Protection Settings**

12V cut-out	12V cut-in	24V cut-out	24V cut-in
10.4	11.7	22.8	24.2

## ABYC Standards - ABYC Guidelines E9 - Direct Current

### Conductor Sizes For 3 Percent Drop in Voltage

		Length of Conductor from Source of Current to Device and Back to Source - Feet																		
		10	15	20	25	30	40	50	60	70	80	90	100	110	120	130	140	150	160	170
TOTAL CURRENT ON CIRCUIT IN AMPS.	<b>12 Volts - 3% Drop Wire Sizes (gauge) - Based on Minimum CM Area</b>																			
	5	18	16	14	12	12	10	10	10	8	8	8	6	6	6	6	6	6	6	6
	10	14	12	10	10	10	8	6	6	6	6	4	4	4	4	2	2	2	2	2
	15	12	10	10	8	8	6	6	6	6	4	4	2	2	2	2	2	1	1	1
	20	10	10	8	6	6	6	6	4	4	2	2	2	2	1	1	1	0	0	0
	25	10	8	6	6	6	4	4	2	2	2	1	1	0	0	0	0	2/0	2/0	3/0
	30	10	8	6	6	6	4	4	2	2	1	1	0	0	0	2/0	2/0	3/0	3/0	3/0
	40	8	6	6	4	4	2	2	1	0	0	0	2/0	2/0	3/0	3/0	4/0	4/0	4/0	4/0
	50	6	6	4	4	2	2	1	0	0	2/0	2/0	3/0	3/0	4/0	4/0	4/0			
	60	6	4	4	2	2	1	0	0	2/0	3/0	3/0	4/0	4/0	4/0					
	70	6	4	2	2	1	0	0	2/0	3/0	3/0	4/0	4/0	4/0						
	80	6	4	2	2	1	0	0	3/0	3/0	4/0	4/0								
	90	4	2	2	1	0	0	2/0	3/0	4/0	4/0									
100	4	2	2	1	0	0	2/0	3/0	4/0	4/0										
<b>24 Volts - 3% Drop Wire Sizes (gauge) - Based on Minimum CM Area</b>																				
5	18	18	18	16	16	14	12	12	12	10	10	10	10	8	8	8	8	8	8	
10	18	16	14	12	12	10	10	10	8	8	8	6	6	6	6	6	6	6	6	
15	16	14	12	12	10	10	8	8	6	6	6	6	6	4	4	4	4	4	4	
20	14	12	10	10	10	8	6	6	6	6	4	4	4	4	2	2	2	2	2	
25	12	12	10	10	8	6	6	6	4	4	4	4	2	2	2	2	2	2	1	
30	12	10	10	8	8	6	6	4	4	4	2	2	2	2	1	1	1	1	1	
40	10	10	8	6	6	6	4	4	2	2	2	1	1	0	0	0	0	0	2/0	
50	10	8	6	6	6	4	4	2	2	1	1	0	0	0	2/0	2/0	2/0	3/0	3/0	
60	10	8	6	6	4	4	2	2	1	0	0	0	2/0	2/0	3/0	3/0	3/0	3/0	3/0	
70	8	6	6	4	4	2	2	1	0	0	0	2/0	2/0	3/0	3/0	3/0	3/0	4/0	4/0	
80	8	6	6	4	4	2	2	1	0	0	0	2/0	2/0	3/0	3/0	3/0	4/0	4/0	4/0	
90	8	6	4	4	2	2	1	0	0	0	2/0	2/0	3/0	3/0	4/0	4/0	4/0	4/0	4/0	
100	6	6	4	4	2	2	1	0	0	2/0	2/0	3/0	3/0	4/0	4/0	4/0	4/0	4/0	4/0	

## ABYC Standards - ABYC Guidelines E8 - Alternating Current/Amperage

### Temperature Rating of Conductor Insulation (Guidelines when using an AC/DC Converter)

Conductor Size (AWG)	60°C (140°F)		75°C (167°F)		80°C (176°F)		90°C (194°F)		105°C (221°F)		125°C (257°F)		200°C (392°F)
	Outside Engine Spaces	Inside Engine Spaces	Outside Engine Spaces	Inside Engine Spaces	Outside Engine Spaces	Inside Engine Spaces	Outside Engine Spaces	Inside Engine Spaces	Outside Engine Spaces	Inside Engine Spaces	Outside Engine Spaces	Inside Engine Spaces	Outside or Inside Engine Spaces
18	7.0	4.1	7.0	5.3	10.5	8.2	14.0	11.5	14.0	11.9	17.5	15.6	17.5
16	10.5	6.1	10.5	7.9	14.0	10.9	17.5	14.4	17.5	14.9	21.0	18.7	24.5
14	14.0	8.1	14.0	10.5	17.5	13.7	21.0	17.2	24.5	20.8	28.0	24.9	31.5
12	17.5	10.2	17.5	13.1	24.5	19.1	28.0	23.0	31.5	26.8	35.0	31.2	38.5
10	28.0	16.2	28.0	21.0	35.0	27.3	38.5	31.6	42.0	35.7	49.0	43.6	49.0
8	38.5	22.3	45.5	34.1	49.0	38.2	49.0	40.2	56.0	47.6	63.0	56.1	70.0
6	56.0	32.5	66.5	49.9	70.0	54.6	70.0	57.4	84.0	71.4	87.5	77.9	94.5
4	73.5	42.6	87.5	65.6	91.0	71.0	94.5	77.5	112.0	95.2	119.0	105.9	126.0
3	84.0	48.7	101.5	76.1	105.0	81.9	108.5	89.0	126.0	107.1	136.5	121.5	147.0
2	98.0	56.8	119.0	89.3	122.5	95.6	126.0	103.3	147.0	125.0	157.5	140.2	168.0
1	115.5	67.0	136.5	102.4	147.0	114.7	147.0	120.5	171.5	145.8	185.5	165.1	196.0
0	136.5	79.2	161.0	120.8	171.5	133.8	171.5	140.6	199.5	169.6	213.5	190.0	227.5
00	157.5	91.4	185.5	139.1	199.5	155.6	199.5	163.6	231.0	196.4	248.5	221.2	259.0
000	182.0	105.6	217.0	162.8	231.0	180.2	231.0	189.4	269.5	229.1	287.0	255.4	301.0
0000	210.0	121.8	252.0	189.0	269.5	210.2	269.5	221.0	311.5	264.8	332.5	295.9	357.0



---

---

## ***Final Installation Notes***

---

- For all appliances, AVOID the use of any electrical adapters or extension cords.
- After installation, allow the appliance to sit for at least one hour before starting.
- **The manufacturer assumes no responsibility for any injuries or damage caused by noncompliance with any of the installation regulations.**

---

# Refrigerators & Freezers • Operation

---

## **Warnings**

This section of the manual refers to essential safety Operation information for all compressor-type refrigerators and freezers (including Portable and Special Purpose Units) provided by Dometic Corporation.

- Before carrying out any maintenance or cleaning operations, disconnect appliance from power supply via the circuit breaker.
- Do not put glass containers holding liquids in the freezer compartment.
- Dispose of packaging material in accordance with local laws for sorted waste recycling.

For any operational problems call your dealer, or call Dometic Corporation at 804-746-1313 or 954-973-2477. Ask for the **Tundra** service department.

---

## Temperature Control

---

Each appliance is fitted with a manual thermostat which automatically maintains set temperatures. There are two (2) types of thermostats. Operation instructions for each are included here.

### **Rotary Thermostat (Knob Control)**

(See Fig. 2, page 19)

1. Select desired temperature by means of the adjustment knob.
2. The refrigerator is STARTED by turning the knob **clockwise**. It clicks "ON." Temperature setting range is shown using a band that thickens in the clockwise direction. The thicker the band, the colder the setting.

Some models are fitted with thermostats with different temperature scale markings than those described above or displayed in Fig. 2. In this case, the temperature is still lowered by turning the knob clockwise.

3. To turn OFF the unit, turn the knob to "0" or "OFF." It clicks "OFF."

---

## **Digital Thermostat (Solid State Control)**

(See Fig. 3, page 20)

- The Digital Thermostat AUTOMATICALLY turns ON when power is applied to unit.
- The thermostat displays the interior temperature constantly.

**To access, and/or change the Setpoint temperature, do the following:**

1. Press the “set” Button to display the Setpoint temperature. The Setpoint is changed with the “up” and “down” Arrow Buttons. The last entered Setpoint will stay in memory. The control automatically returns to NORMAL mode (displaying the interior temperature) within 5 seconds.
2. Press the “up” Button to INCREASE Setpoint temperature. When held down for a few seconds, the change rate accelerates.
3. Press the “down” Button to DECREASE Setpoint temperature. When held down for a few seconds, the change rate accelerates.

---

## **Loading the Appliance**

---

All materials exposed to contact with food comply with EC directive 89/109.

Once the thermostat is set to a desired temperature, allow the unit to RUN at least 12 hours (24 hours for best results) before loading it with goods.

**For proper food storage and conservation refer to the table below:**

<b>Food</b>	<b>Storage Time</b>	<b>Position In Appliance</b>
Meat or fish properly wrapped in plastic	2 to 3 days	On the rack under the freezer compartment
Eggs	1 week	Use door compartment
Butter, margarine	1 week	Use door compartment
Cooked food, cakes and soups (in sealed containers and cooled)	3 to 4 days	On the lowest rack in the refrigerator
Cold cuts, cheese, fresh pasta, pastries, cream, tomatoes, puddings, chocolates, lard	3 to 4 days	On any rack
Fruit and vegetables	1 week	In the bottom of the refrigerator

---

# Refrigerators & Freezers • Maintenance

---

## Defrosting

---

Defrosting should be carried out whenever the frost layer exceeds a thickness of 1/8 of an inch. This is necessary to guarantee efficient refrigeration and to avoid excessive power consumption. Excess frost buildup will effect the appliance's performance.

To completely defrost, turn the appliance OFF. Keep the door/lid open to minimize the defrosting time.

Do not attempt to remove the frost layer using any sharp metal instruments. This could pierce the appliance plate and cause irreparable damage to the appliance.

After defrosting, dry the entire interior surfaces, and then turn the appliance ON.

---

## Cleaning

---

Before cleaning, disconnect the appliance from the power supply. If necessary, remove the plug from the power socket.

### ***Cleaning the Exterior***

Clean the exterior with warm and then with cold water. Dry with a soft cloth. Avoid use of abrasive products.

### ***Cleaning the Interior***

Remove racks, containers, and ice trays. Clean the interior using warm water mixed with baking soda or vinegar. Rinse and dry carefully with a soft cloth. Do not use abrasive products, detergents or soap. In the case of prolonged disuse, to avoid the formation of mold or unpleasant odors, remove plug from socket, empty the unit completely, clean the interior, and leave the door/lid ajar.

### ***Cleaning the Condenser***

Clean the condenser at least once a year using a vacuum cleaner or dry brush. Do not clean with sharp objects.

---

# Refrigerators & Freezers • Trouble-Shooting

---

## A. Appliance Does Not Operate

Check that:

1. The thermostat is not set to “STOP” or “OFF”.
2. The electrical system circuit-breaker for the appliance is “ON”.
3. The fuse between the electronic control unit and the power source has not blown.
4. The power supply cable is not faulty, loose or poorly connected.
5. The battery is delivering sufficient power. If the battery voltage is less than 10.4V (on a 12VDC system) or 22.8V (on a 24VDC system), the unit will not operate.
6. The voltage on the electronic control unit terminal board corresponds to that of the battery. If there is a voltage drop of over 0.2-0.4V check that:
  - a. The size of the cable connecting the battery to the electronic control unit corresponds to specifications (see ABYC Guidelines).
  - b. All connection points in the power supply are properly tightened.
  - c. There are no signs of oxidation on the battery poles and contact points.
7. If an AC/DC converter is being used, check that:
  - a. The AC power source is “ON”.
  - b. The circuit board terminals are properly connected.
  - c. Output voltage to the appliance is sufficient.

## B. Excessive Appliance Noise

Check that:

1. The appliance and refrigerating unit are positioned on flat surfaces.
2. The appliance is not touching other objects that may cause vibration.
3. The refrigerant lines at the back of the unit (if applicable) are not touching or vibrating against the appliance.

---

### **C. Insufficient Refrigerating Capacity**

Check that:

1. The door/lid is sealed properly.
2. The appliance is not positioned close to heat sources.
3. The appliance and remote refrigerating unit (if applicable) are sufficiently ventilated.
4. Excess frost has not accumulated on the evaporator.
5. Dust has not blocked the condenser.
6. The fan rotates freely (in forced air models).
7. The appliance is not over-full.

**If, after checking the above, the appliance still does not function, call your service dealer or Dometic Corporation at 804-746-1313 or 954-973-2477. Ask for the Tundra service department.**

---

## Manufacturer's Limited Warranty Agreement

The following warranty is extended to cover Tundra products supplied by Dometic Corporation and is subject to qualifications indicated. Dometic Corporation warrants for the periods set forth below that products manufactured or supplied by it will be free from defects in workmanship and material, provided such products are installed, operated, and maintained in accordance with Dometic Corporation written instructions.

All implied warranties, including merchantability and fitness for a particular purpose, are limited to the terms and periods of warranty set forth below and, to the extent permitted by law, any and all implied warranties are excluded.

**Note: The warranty described below is for all segments of the marine pleasure boat industry only. There are significant timing issues for other industries. Consult your source of purchase if you have a unit installed into other applications (trucks, recreational vehicles, etc.). Warranties may be tied to chronological events, mileage, etc., and provide for different coverages.**

New units are warranted for a period of two (2) years from the date of installation for all parts, not to exceed three (3) years from the date of manufacture.

Labor will be paid as outlined in the **Schedule of Limited Warranty Allowances** for removal and reinstallation of such components for a period of one (1) year from the date of installation. **OEM installed equipment** warranties begin with the purchase of the vessel or vehicle, not from the date of installation. Warranty will be paid in accordance with our established schedule of allowances. Compensation for warranty repairs is only made to Dometic Corporation authorized service companies.

Dometic Corporation will repair or replace, at its option, components found to be defective due to faulty materials or workmanship, when such components, examined by an authorized service dealer or a factory service representative, are found to have a defect for which the company is responsible. Replacement components are warranted for the duration of the remaining warranty period in effect on the original component.

The limited warranty is extended in lieu of all other warranties, agreements or obligations, expressed or implied, concerning Tundra's components. This warranty is extended only to the original purchaser and is not transferable. This warranty shall be governed by the laws of the State of Florida and gives the original first end user definite legal rights.

This warranty does not cover damages incidental and/or consequential to the failure of Dometic Corporation's equipment including but not limited to the following: normal wear, accident, misuse, abuse, negligence, improper installation, lack of reasonable and necessary maintenance, alteration, civil disturbance or acts of God.

No person or dealer is authorized to extend any other warranties or to assume any other liabilities on Dometic Corporation's behalf, unless made or assumed in writing by an officer of Dometic Corporation.

## Dometic Corporation – Tundra Schedule of Limited Warranty Allowances

This schedule lists the maximum Dometic Corporation allowance for the repairs listed below. **Items which exceed the scheduled allowances require prior approval.** Sales tax, duty, mileage charges, tolls, phone calls, etc. are not covered by warranty and are the responsibility of the customer. If more than one repair is performed during the same visit, Dometic Corporation will pay 100% of the first covered repairs and 50% for all others. This warranty does not cover incidental and/or consequential items to the failure of Tundra’s refrigeration equipment.

Warranty Service Performed	Labor Allowance Marine Industry	Labor Allowance Trucking Industry
Unit change out	3.5 hours	1.5 hours
Thermostat change out	2.5 hours	1.0 hours
Electronic Module change out	2.5 hours	1.5 hours
Door change out	2.0 hours	1.0 hours
Power supply change out	2.5 hours	1.0 hours
Resistor (speed setting) change out	2.0 hours	0.5 hours
Fan Motor change out	2.5 hours	1.5 hours
Door lock change out	1.5 hours	0.5 hours

### CUSTOMER RESPONSIBILITIES

1. Verify the product’s purchase date for warranty purpose.
2. Pay for normal operational maintenance, cleaning or adjustments.
3. Pay for damage repairs resulting from unauthorized modifications, improper electrical supply or damage by fire, storm or other acts of God.
4. Pay for premium labor rates, excessive mileage or miscellaneous tools and material charges not listed, and additional labor charges resulting from the inaccessibility of the unit for service.



---

# WARNING

Dometic Corporation, manufacturers of Cruisair, Grunert, Marine Air, Sentry and Tundra Products, makes the following safety warnings concerning the application, installation, use and care of its products. Although these warnings are extensive, there may be specific hazards which may arise out of circumstances which we have not outlined herein. Use this as a guide for developing an awareness of potential hazards of all kinds. Such an awareness will be a key factor in assuring your SAFETY and comfort.

**ELECTRICITY** - Many Dometic products operate on 115, 230 or 440 volt AC power and/or 12/24 volt DC power. Such voltages can be LETHAL; therefore, the chassis, cabinets, bases, etc., on all components must be grounded together and connected to the vessel's or vehicle's grounding system. Sparks can occur as switches, thermostats and relays open and close in the normal operation of the equipment. Since this is the case, ventilating blowers for the removal of hazardous fumes or vapors should be operated at least 5 minutes before and during operation of any Dometic product or group of Dometic products. All electrical connections must be covered and protected so accidental contact cannot be made by persons using the equipment, as such contact could be LETHAL.

**ELECTROLYSIS** - Electrical leakage of any component can cause electrolytic deterioration (electrolysis) of thru-hull components which could result in leakage serious enough to sink a vessel which could result in loss of life. All Dometic components must be kept clean and dry and checked periodically for electrical leakage. If any electrical leakage is detected, the component should be replaced or the fault causing the leakage corrected before the component is put back into service.

**GAS** - CRUISAIR, MARINE AIR, GRUNERT and TUNDRA components utilize R134a refrigerant, R409A or R404A, R417A, R407C and R22. These are non-toxic, non-flammable gases. However, these gases contain no oxygen and will not support life. Refrigerant gas tends to settle in the lowest areas of the compartment. If you experience a leak, evacuate all personnel, and ventilate area. Do not allow open flames in the area of leaks because refrigerant gas, when burned, decomposes into other potentially LETHAL gases. Refrigerant components operate at high pressure and no servicing should be attempted without gloves, long-sleeved clothing and eye protection. Liquid refrigerant gas can cause severe frost burns to the skin and eyes.

**VENTILATION** - CRUISAIR, MARINE AIR, GRUNERT and TUNDRA components are designed to move air through a heat exchanger by a blower or propeller fan. This design necessarily produces a suction on one side of the air handling component and a pressure on the other side. Air handling components must be installed so that the suction-pressure action does not: (1) pressurize an area to the extent that structural failure occurs which could cause harm to occupants or bystanders, or (2) cause a suction or low pressure in an area where hydrogen gas from batteries, raw fuel vapor from fuel tanks, carbon monoxide from operating propulsion engines, power generators or heaters, methane gas from sewage holding tanks, or any other dangerous gas or vapor could exist. If a unit is installed in such a manner that allows potentially lethal gases or vapors to be discharged by the air handling unit into the living space, this could result in loss of life.

Maximum protection against the introduction of dangerous gases or vapors into living spaces can be obtained by providing living spaces which are sealed from all other spaces by use of airtight bulkheads and decks, etc., and through the introduction of clean air into the living space. Bear in mind that the advent of air conditioning, whether it be for cooling or for heating, naturally leads to the practice of closing a living space tightly. Never close all windows and doors unless auxiliary ventilating systems, which introduce clean outside air into the living space, are used. Always leave enough window and door openings to provide adequate ventilation in the event potentially lethal gases or fumes should escape from any source.

**CONDENSATE** - All cooling units produce water condensate when operating on the cooling cycle. This water must be drained from the cooling unit overboard. If condensate is allowed to drip on a wooden structure, rotting or decay and structural failure may occur which could result in loss of life. If condensate is allowed to drip on electrical components, deterioration of the electrical components could result in hazardous conditions. When an air conditioning system is in operation, condensate drains may be subjected to negative pressure. Always locate condensate drains as far as possible from points where engine waste and other dangerous gases are exhausted so no such dangerous gases can be drawn into the condensate drains.

## Warning

Never sleep in a closed area on a boat or vehicle when any equipment, which functions as a result of the combustion of a volatile fuel, is in operation (such as engines, generators, power plants, or oil-fired heaters, etc.) At any time, the exhaust system of such devices could fail, resulting in a build-up of LETHAL gases within the closed area.

---

## Description of Drawings/Diagrams

---

### Fig. 1 Description of an Appliance (1 - 8)

1. Mounting Flange Assembly
2. Freezer Compartment w/ Door
3. Condensation Drain Pan
4. Vinyl Coated Wire Shelf(s) (Adjustable)
5. Glass shelf
6. Door Shelves/Bottle Compartments
7. Positive Locking Door (Nautic Lock)
8. Thermostat

### Fig. 2 Rotary Thermostat

1. Coldest Setting
2. Adjustment Knob, Turn Clockwise

### Fig. 3 Digital Thermostat

1. "up" Button
2. "down" Button
3. "set" Button

### Fig. 4 Portable Unit Cable with 12V Plug

### Fig. 5 G1030011A Tundra Ventilation Requirements

### Fig. 6 G1010057A DC Only Wiring Diagram

### Fig. 7 G1010050C TPS AC/DC Power Supply Wiring Diagram

### Fig. 8 G1010058 Digital Thermostat - TPD23 (DC only) Wiring Diagram

### Fig. 9 G1010059A Digital Thermostat - TPD23AC (AC/DC) Wiring Diagram

### Fig. 10 G1030029 Latch Redesign Schematic

**Fig. 1**

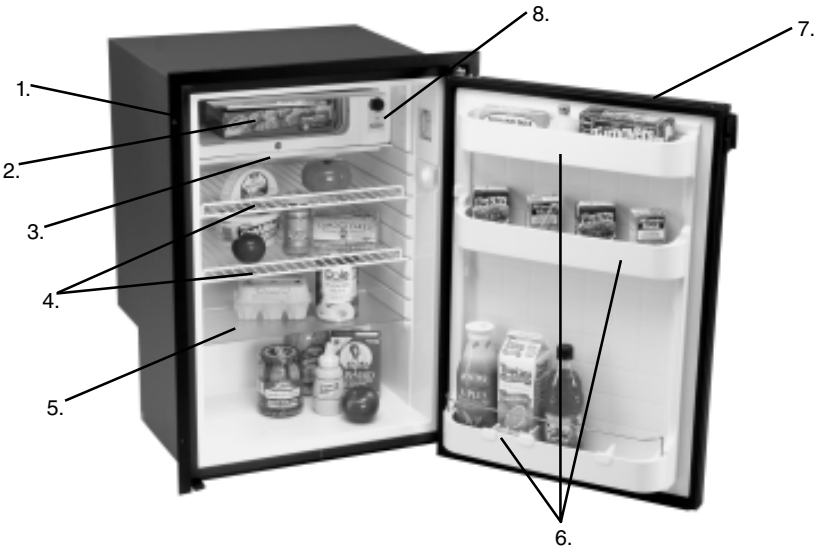

**Fig. 2 Rotary Thermostat**

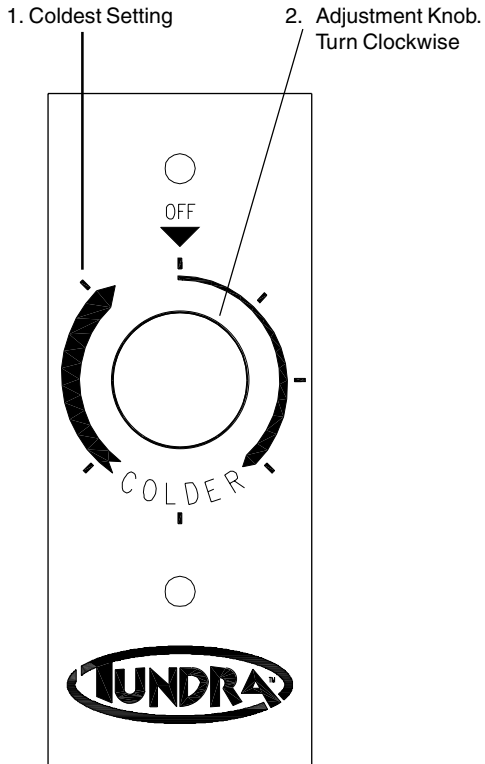

**Fig. 3 Digital Thermostat**

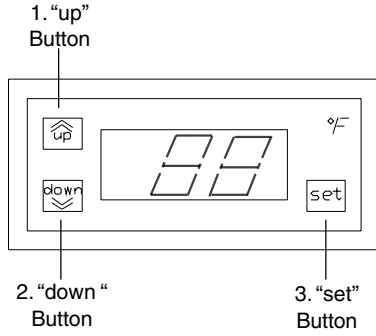

**Fig. 4 Portable Unit Power Conections**

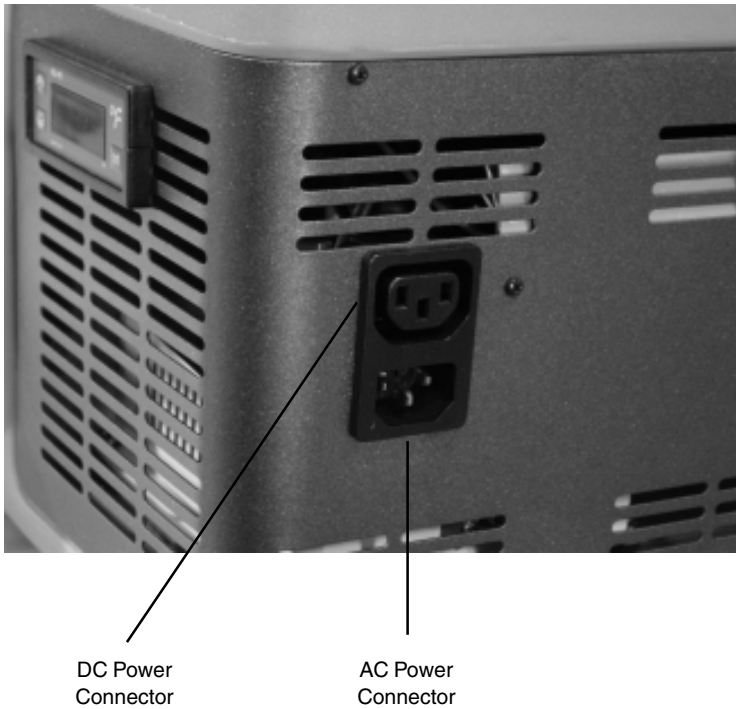

**Fig. 5 Tundra Ventilation Requirements**

PERMANENTLY NOTE THE IMPROVEMENTS THEREIN WITHIN THIS DOCUMENT IS THE PROPERTY OF DOMETIC CORPORATION. ANY ATTEMPT TO COPY OR DISTRIBUTE WITHOUT WRITTEN CONSENT OF DOMETIC CORPORATION IS PROHIBITED. DOMETIC, THE LOGO AND NAME CAN BE REGISTERED IN A COURT OF LAW.

REV	DATE	REVISION	DWG	APR
A	7/19/02	ADDED TEXT "OR" CAD409-02	DRR	DTS

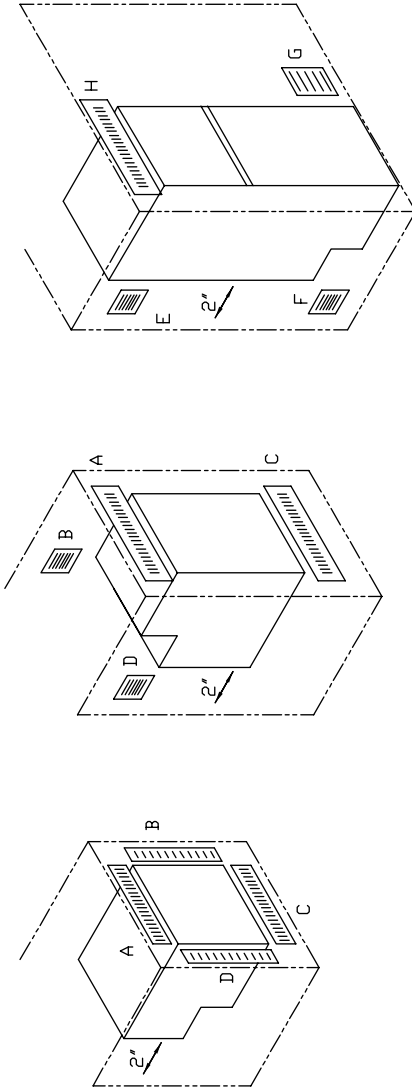

EXAMPLES:

ALL UNITS EXCEPT T80

- A AND C - PAIR OF GRILLS = 50 SQ. IN. MINIMUM, OR
  - B AND D - PAIR OF GRILLS = 50 SQ. IN. MINIMUM, OR
  - A OR B - SINGLE GRILL = 50 SQ. IN. MINIMUM
- EXAMPLES:
- T80
  - E AND F - PAIR OF GRILLS = 75 SQ. IN. MINIMUM, OR
  - G OR H - SINGLE GRILL = 75 SQ. IN. MINIMUM

NOTE: UNITS WITH REMOTE MOUNTED CONDENSING ASSEMBLIES REQUIRE THE SAME MINIMUM VENTILATION.

DRAWING NO:	REV:
G1030011A	A

DATE:	11/7/01
SCALE:	N.T.S.
PART NUMBER:	T80
DRAWN BY:	DRR
APPROVED BY:	DTS
DRAWING NO:	G1030011A
REV:	A
SIZE:	A

VENTILATION REQUIREMENTS  
**TUNDRA**

**DOMETIC-TUNDRA**

CRUISAIR-MARINE AIR-GRUNERT-SENTRY-TUNDRA

**Fig. 6 DC Only Wiring Diagram**

PROPRIETARY NOTE: THE INFORMATION CONTAINED WITHIN THIS DOCUMENT IS THE PROPERTY OF DOMETIC CORPORATION. ANY ATTEMPT TO COPY OR DISTRIBUTE WITHOUT WRITTEN CONSENT FROM DOMETIC CORPORATION SHALL BE CONSIDERED UNLAWFUL AND CAN BE CONTESTED IN A COURT OF LAW.

REV	DATE	REVISION	DWG	APR
A	12/5/01	ADD WIRE COLORS, CAD1221-01	DRR	DTS

Plotted:  
06 Dec 01 -- 08:05 am

DWG CREATED BY CAD743-01

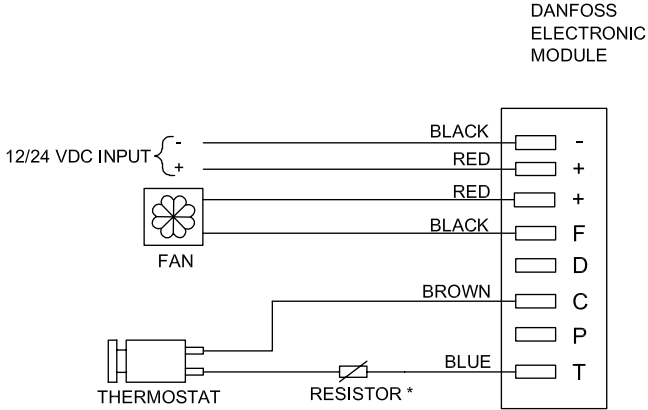

\* RESISTORS ARE USED TO CONTROL COMPRESSOR SPEED (R.P.M.)  
SOME UNITS DO NOT USE A RESISTOR.

DATE: 7/24/01	WIRING DIAGRAM TUNDRA	<b>DOMETIC-TUNDRA</b>
PART NUMBER: T.B.D.	DC ONLY WIRING	
SCALE: N.T.S.	DRAWING NO: G1010057A	
DRAWN BY: DRR	APPROVED BY: DTS	CRUISAIR-MARINE AIR-GRUNERT-SENTRY-TUNDRA

**Fig. 7 TPS AC/DC Power Supply**

PROPRIETARY NOTE: THE INFORMATION CONTAINED WITHIN THIS DOCUMENT IS THE PROPERTY OF DOMETIC CORPORATION, ANY ATTEMPT TO COPY OR DISTRIBUTE WITHOUT WRITTEN CONSENT FROM DOMETIC CORPORATION SHALL BE CONSIDERED UNLAWFUL AND CAN BE CONTESTED IN A COURT OF LAW.

REV	DATE	REVISION	DWG	APR
A	7/24/01	ADDED RESISTOR,THERMOSTAT & FAN,DCR742-01	DRR	DTS
B	12/5/01	UPDATE WIRE CONNECTIONS,CAD1220-01	DRR	DTS
C	10/17/02	UPDATED TPS BOARD,CAD619-02	DRR	DTS

Plotted:  
17 Oct 02 - 03:22 pm

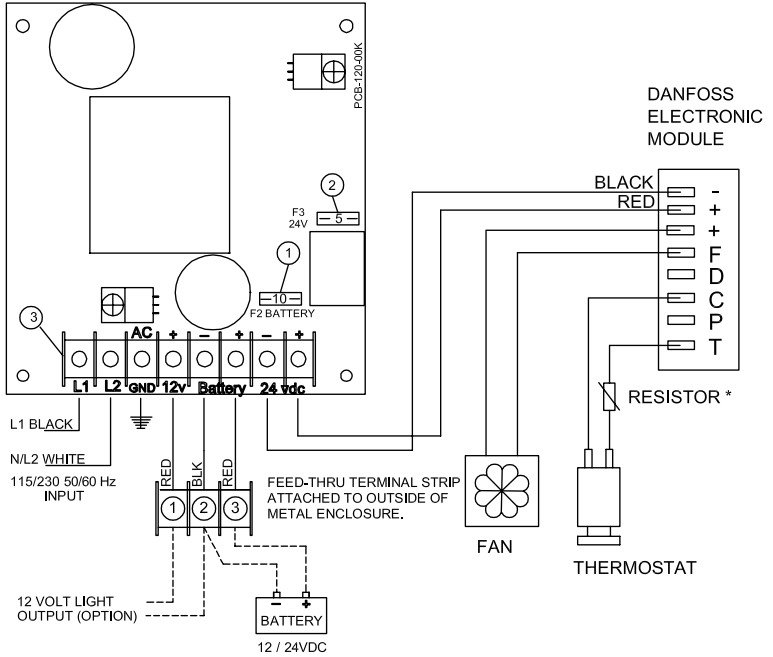

\* RESISTORS ARE USED TO CONTROL COMPRESSOR SPEED (R.P.M.)  
SOME UNITS DO NOT USE A RESISTOR

DATE: 7/19/00	WIRING DIAGRAM TUNDRA TPS AC/DC POWER SUPPLY		DOMETIC-TUNDRA CRUISAIR-MARINE AIR-GRUNERT-SENTRY-TUNDRA	
PART NUMBER: T.B.D.				
SCALE: N.T.S.				
DRAWN BY: MJS	APPROVED BY: DTS	DRAWING NO: G1010050C	REV: C	SIZE: A

**Fig. 8 Digital Thermostat - TPD23 (DC only) Wiring Diagram**

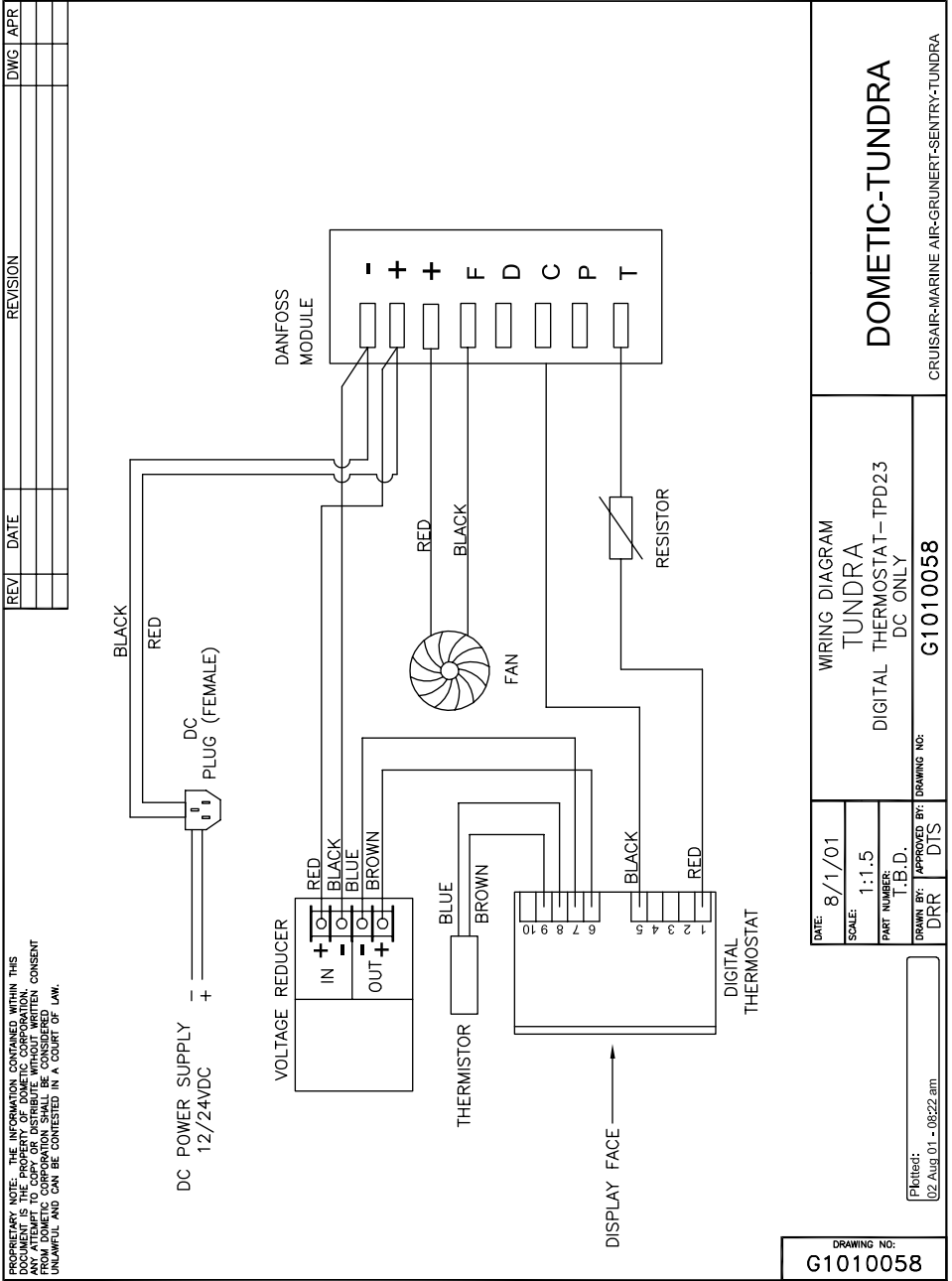

<p>DATE: 8/1/01</p> <p>SCALE: 1:1.5</p> <p>PART NUMBER: T.B.D.</p> <p>DRAWN BY: DRR</p> <p>APPROVED BY: DTS</p>	<p style="text-align: center;">WIRING DIAGRAM</p> <p style="text-align: center;">TUNDRA</p> <p style="text-align: center;">DIGITAL THERMOSTAT-TPD23</p> <p style="text-align: center;">DC ONLY</p>	<p style="text-align: center; font-size: 24pt; font-weight: bold;">DOMETIC-TUNDRA</p> <p style="text-align: right; font-size: 10pt;">CRUISAIR-MARINE AIR-GRUNERT-SENTRY-TUNDRA</p>
<p>Plotted: 02 Aug 01 - 08:22 am</p>		<p style="text-align: center; font-weight: bold;">G1010058</p>



**Fig. 9 Digital Thermostat - TPD23AC (AC/DC) Wiring Diagram**

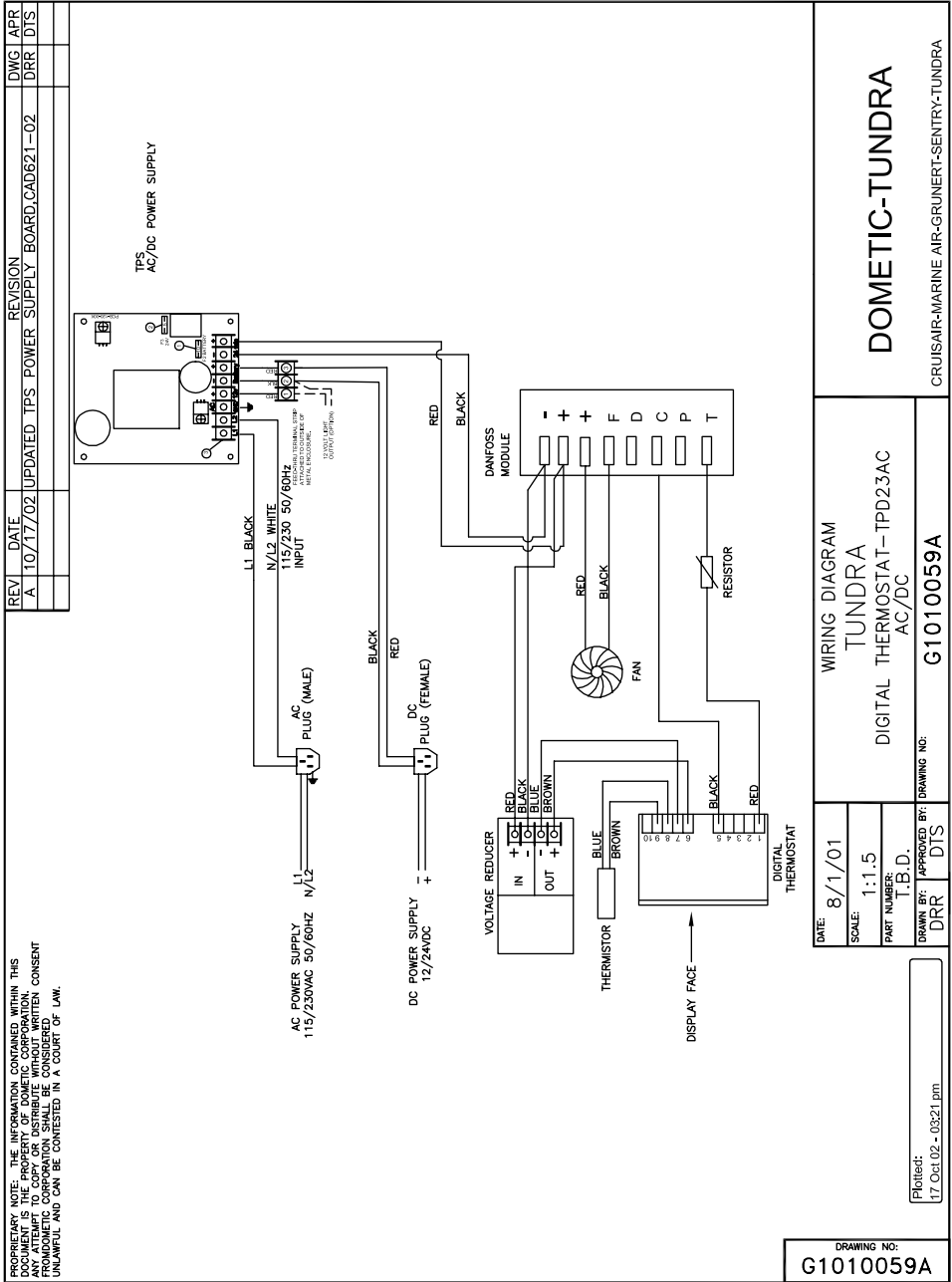

**Fig. 10 Latch Redesign Schematic**

PROPRIETARY NOTE: THE INFORMATION CONTAINED WITHIN THIS DOCUMENT IS THE PROPERTY OF DOMETIC CORPORATION. ANY ATTEMPT TO COPY OR DISTRIBUTE WITHOUT WRITTEN CONSENT FROM DOMETIC CORPORATION SHALL BE CONSIDERED UNLAWFUL AND CAN BE CONTESTED IN A COURT OF LAW.

REV	DATE	REVISION	DWG	APR

T-TSL  
COMPLETE  
ASSEMBLY

Part no  
6-11c1-03 - 0214.m

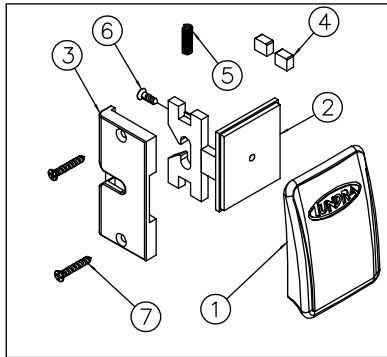
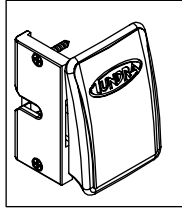

NO.	DESCRIPTION	QTY
1	HANDLE W/LOGO	1
2	BACK PLATE FOR HANDLE	1
3	LATCH COVER	1
4	SPACERS	2
5	SPRING	2
6	HANDLE SCREW	2
7	MOUNTING SCREWS	1

DATE:  
10/14/03  
PART NUMBER:  
T.B.D.  
SCALE:  
N.T.S.

T-TSL  
TUNDRA LATCH ASSEMBLY

**DOMETIC-TUNDRA**

DRAWN BY:  
DRR  
APPROVED BY:  
DTS

DRAWING NO:  
**G1030029**

CRUISAIR-MARINE AIR-GRUNERT-SENTRY-TUNDRA



Place  
Data Label  
Here



**Dometic Corporation**

2000 N. Andrews Ave. Ext. • Pompano Beach, FL 33069-1497 USA  
954-973-2477 • Facsimile: 954-979-4414 • [www.tundra.cc](http://www.tundra.cc)

P.O. Box 15299 • Richmond, VA 23227-0699 USA  
804-746-1313 • Facsimile: 804-746-7246



The Sign of Comfort

L-0938